

1 360\_ELEVATION\_TYPICAL SLIDING DOOR  
A401 1:20

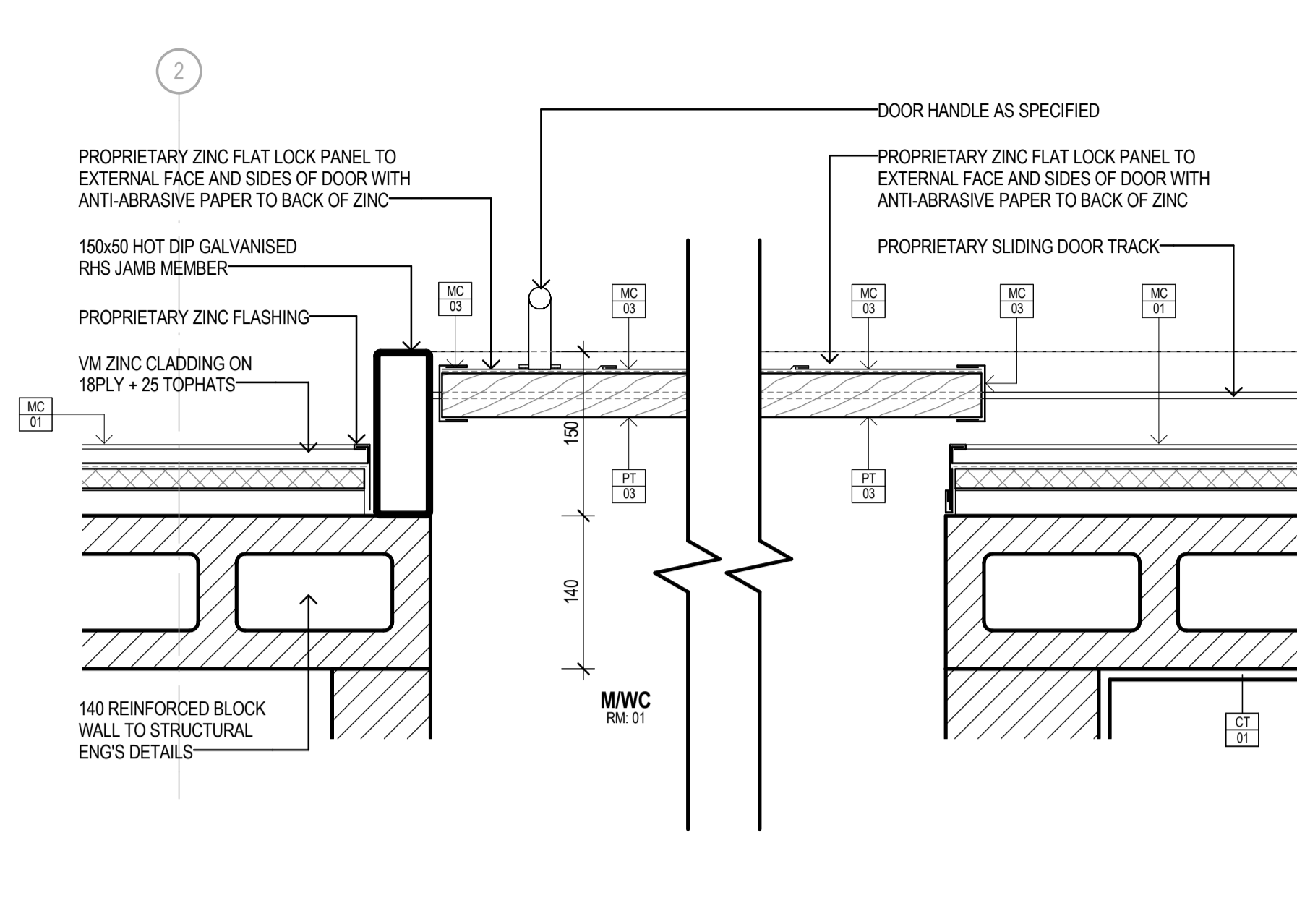

4 630\_PLAN\_TYPICAL SLIDING DOOR JAMB DETAILS  
A801 1:5

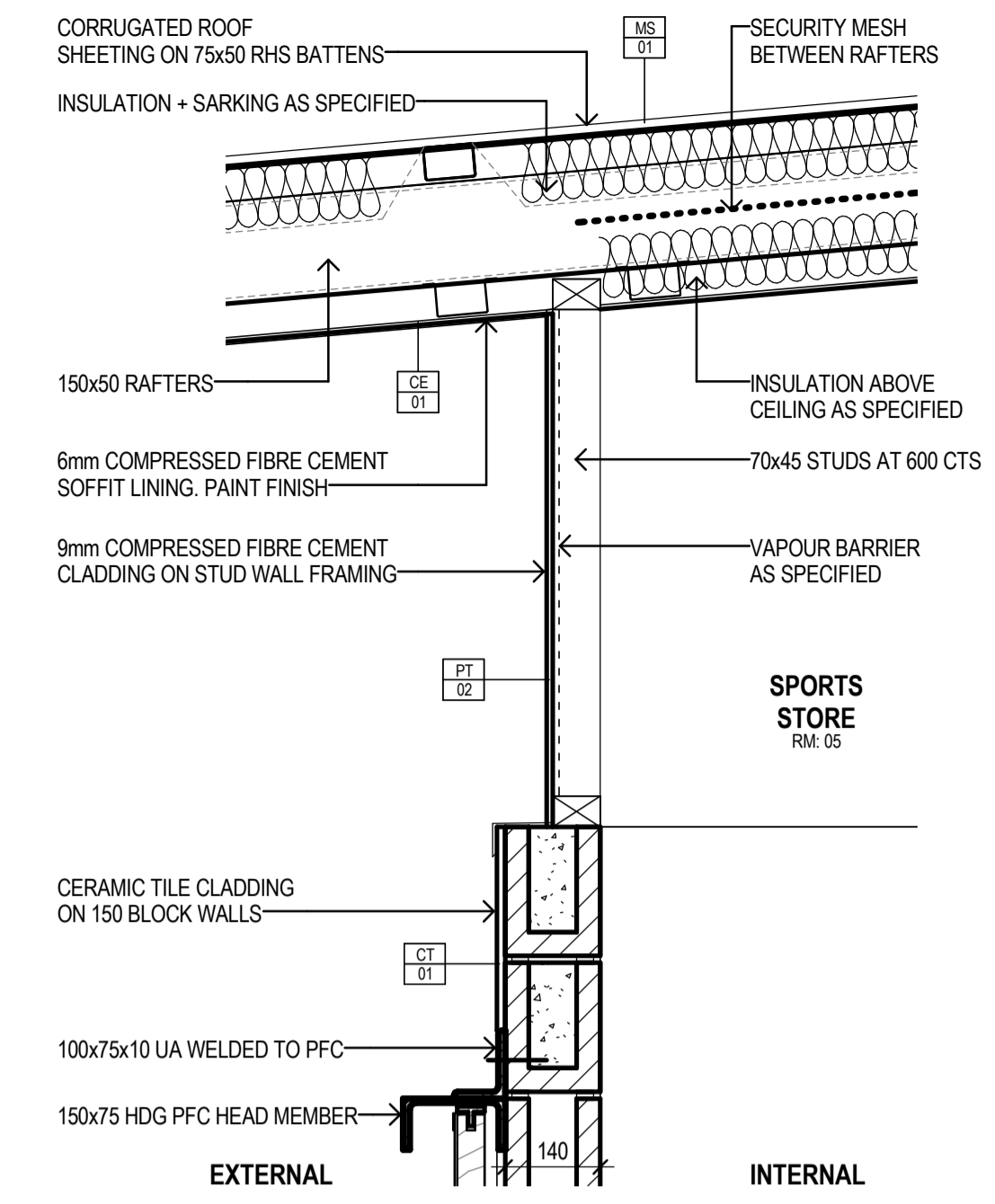

9 630\_SECTION\_TYPICAL DETAIL FC SPANDEL  
A501 1:10

Notes  
The information contained in this document is copyright and may not be used or reproduced for any other project or purpose.  
Verify all dimensions and levels on site and report any discrepancies to dwp/suters for direction prior to the commencement of work.  
Drawings are to be read in conjunction with all other contract documents.  
Use figured dimensions only. Do not scale from drawings. dwp/suters cannot guarantee the accuracy of content and format for copies of drawings issued electronically.  
The completion of the Issue Details Checked and Authorised section is confirmation of the status of the drawing. The drawing shall not be used for construction unless endorsed 'For Construction' and authorised for issue.  
© SUTERS ARCHITECTS PTY LTD trading as dwp/suters ABN 83 129 614 713 Robert Macrobee Nominated Architect NSW APR 4699

NOTES:  
1- FOR ALL WALL AND FLOOR FINISHES CODES PLEASE REFER TO SPECIFICATION AND FINISHES SCHEDULE.  
2- DIMENSIONS TAKEN FROM THE CORE FACE OF WALLS.

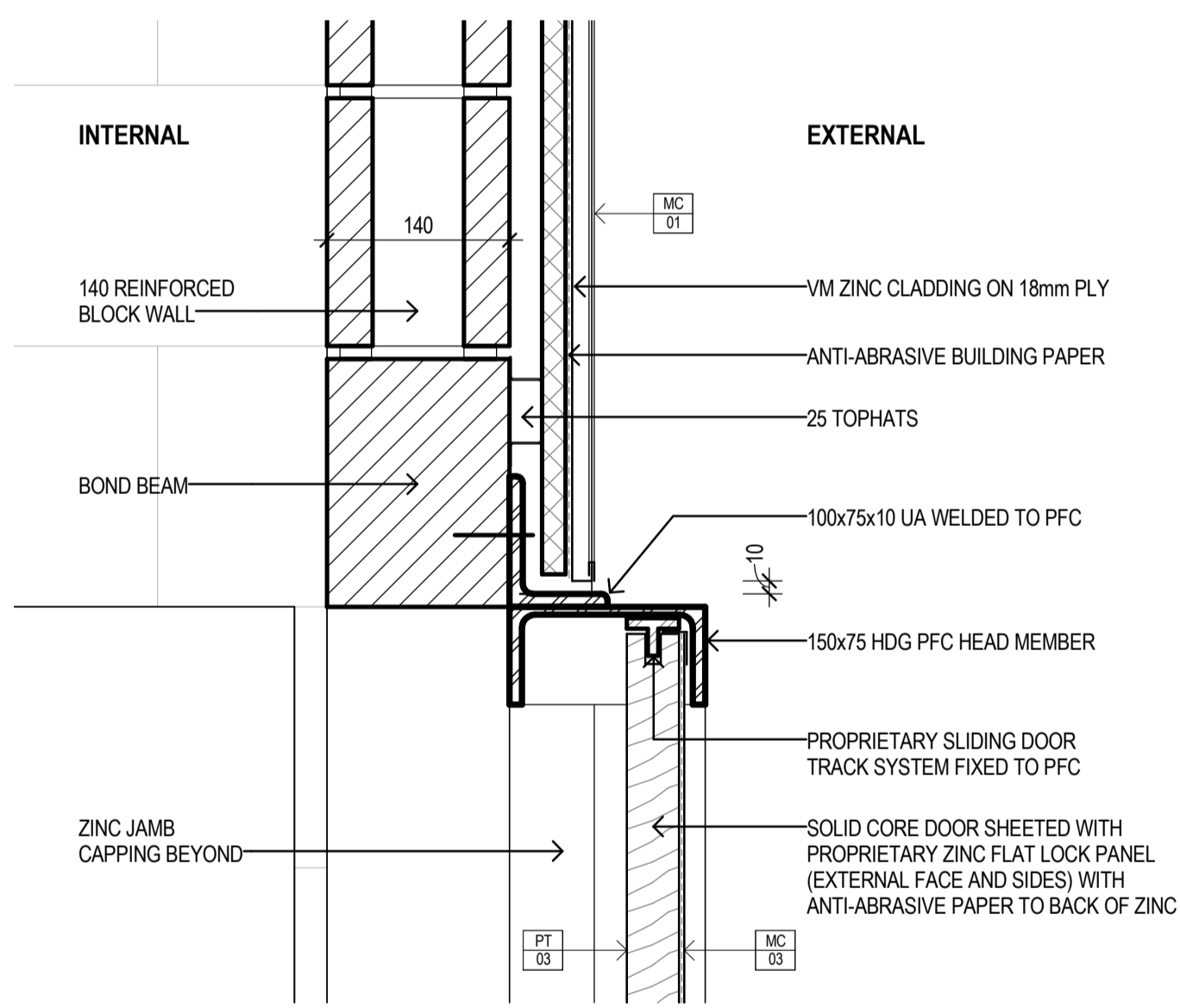

2 630\_SECTION\_TYPICAL SLIDING DOOR HEAD DETAIL  
A501 1:5

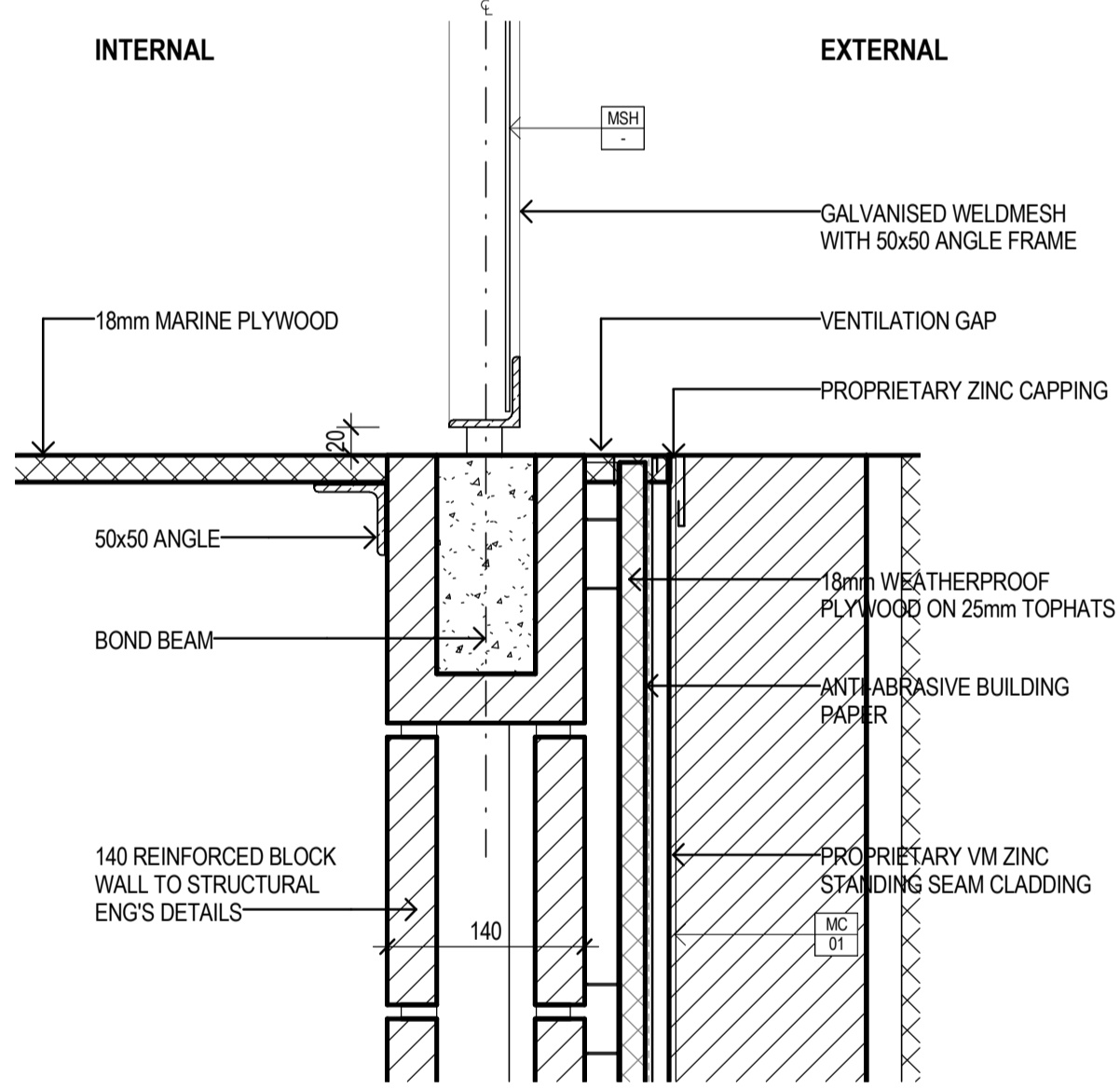

5 630\_SECTION\_TYPICAL ZINC CLADDING DETAILS (TOP)  
A501 1:5

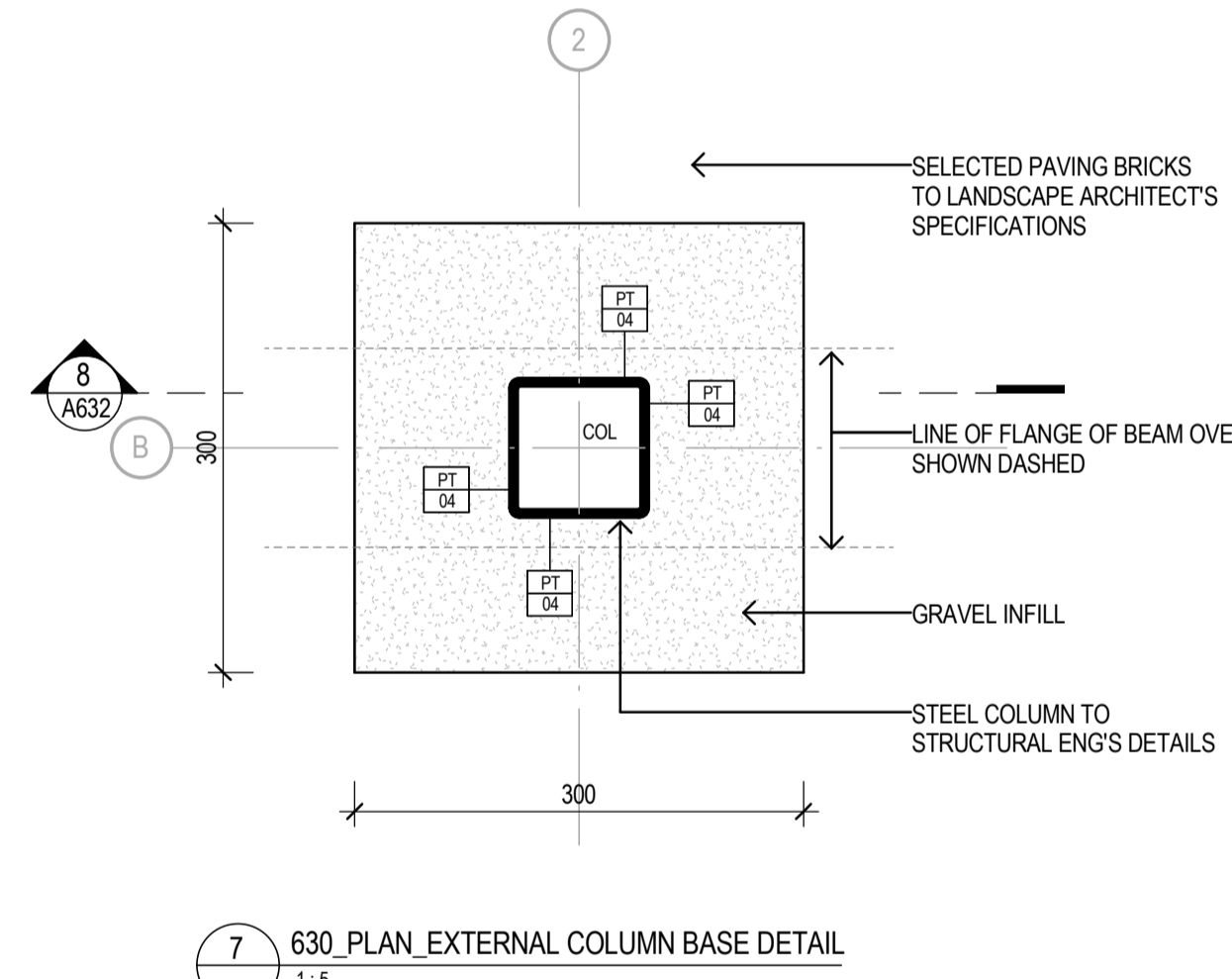

7 630\_PLAN\_EXTERNAL COLUMN BASE DETAIL  
1:5

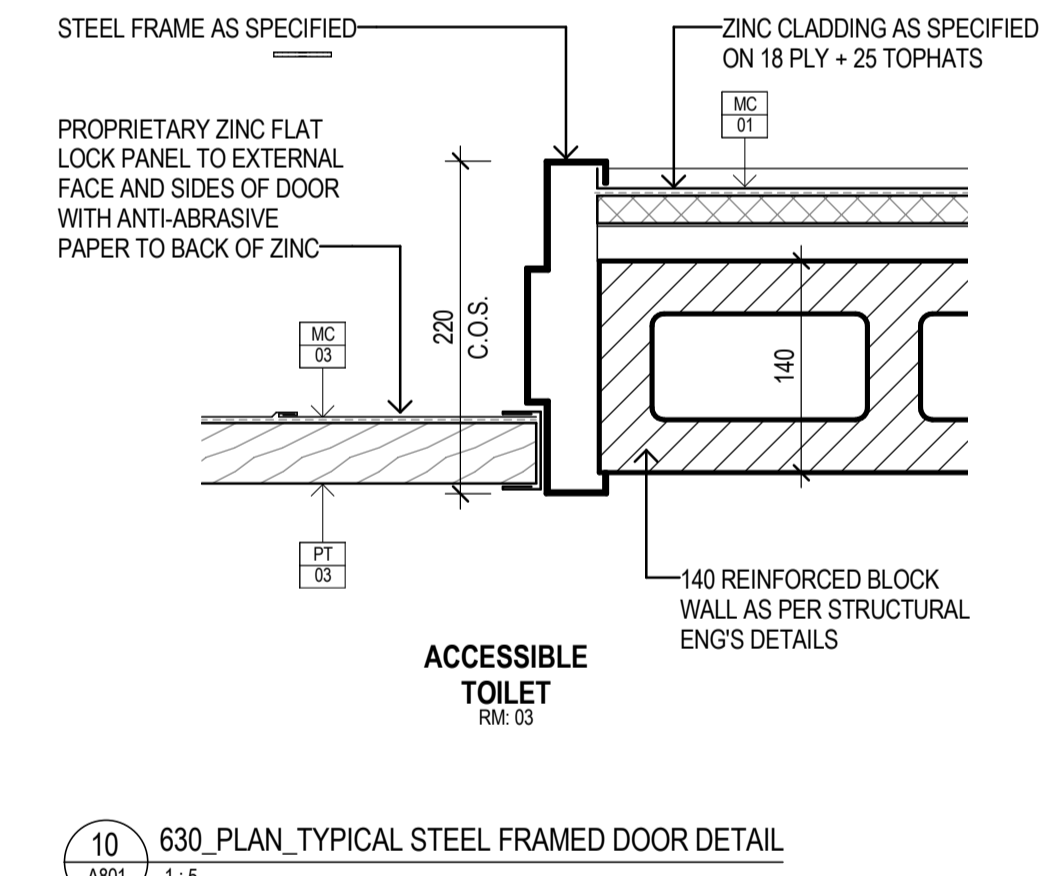

10 630\_PLAN\_TYPICAL STEEL FRAMED DOOR DETAIL  
A801 1:5

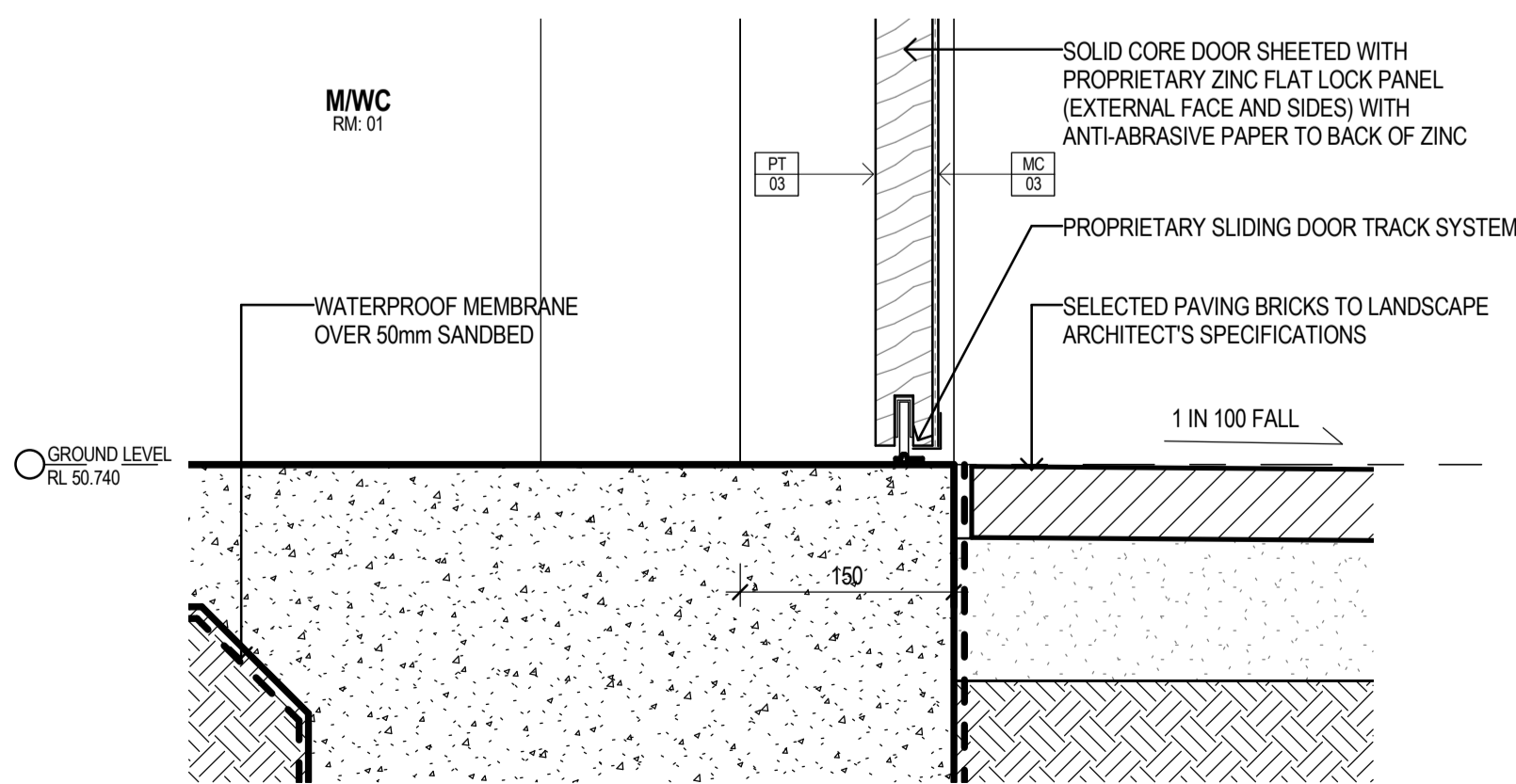

3 630\_SECTION\_TYPICAL SLIDING DOOR BOTTOM DETAIL  
A501 1:5

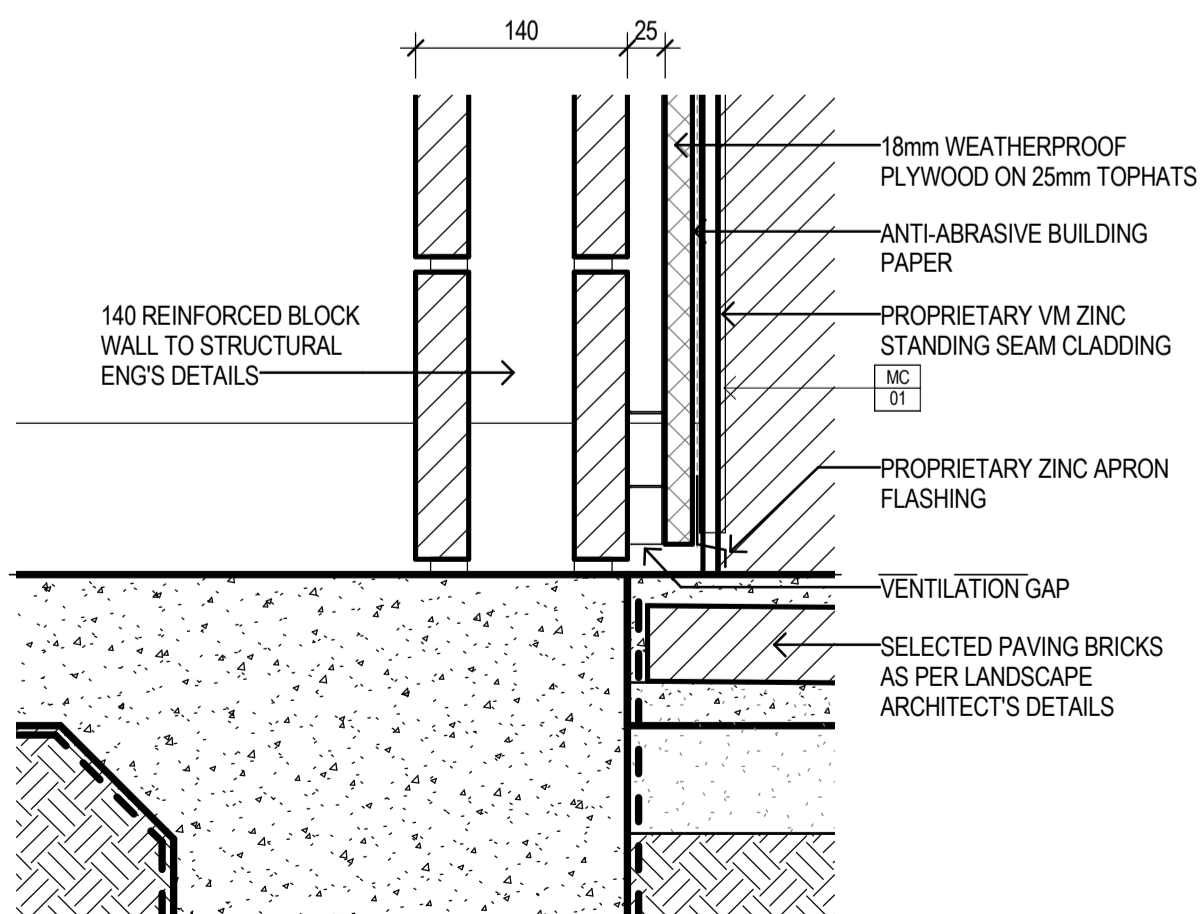

6 630\_SECTION\_TYPICAL ZINC CLADDING DETAILS (BOTTOM)  
A501 1:5

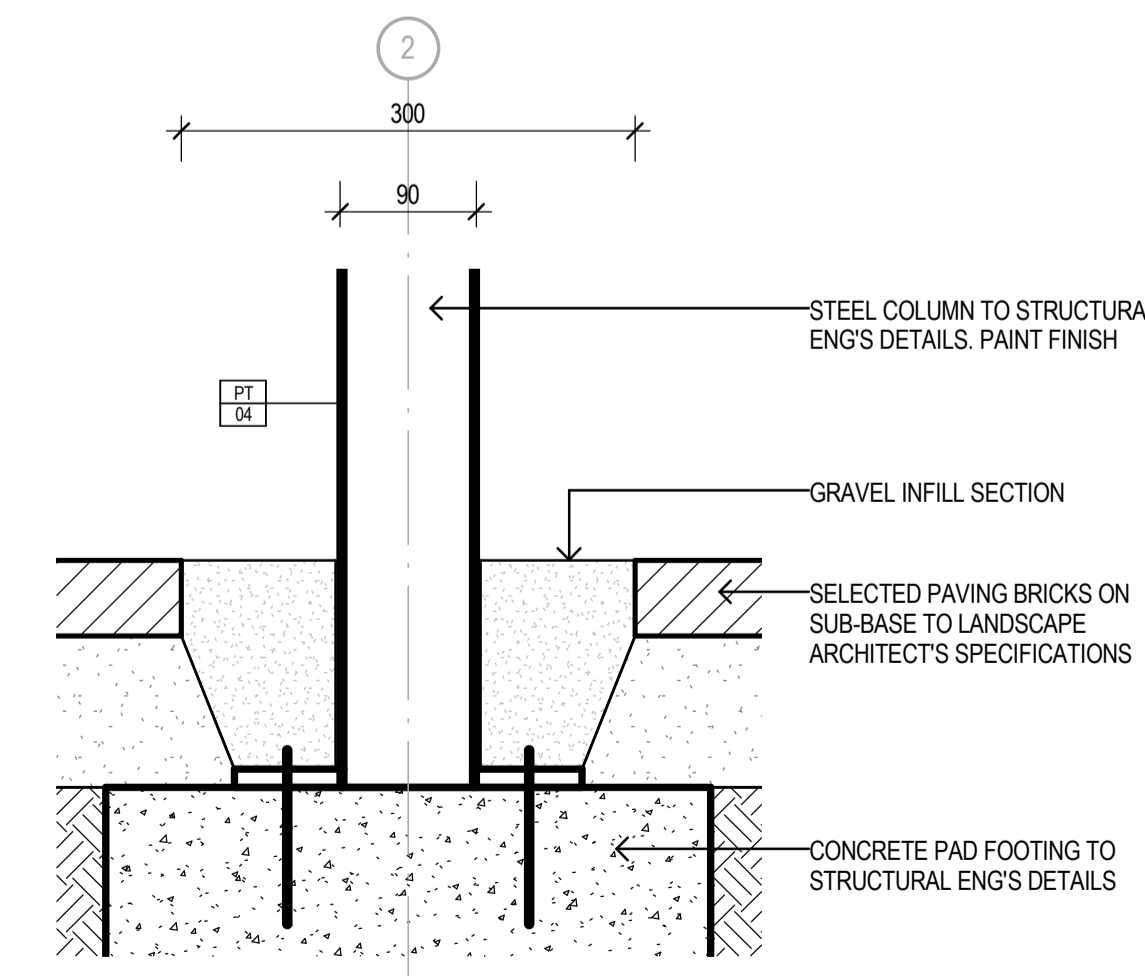

8 630\_SECTION\_EXTERNAL COLUMN BASE DETAIL  
A632 1:5

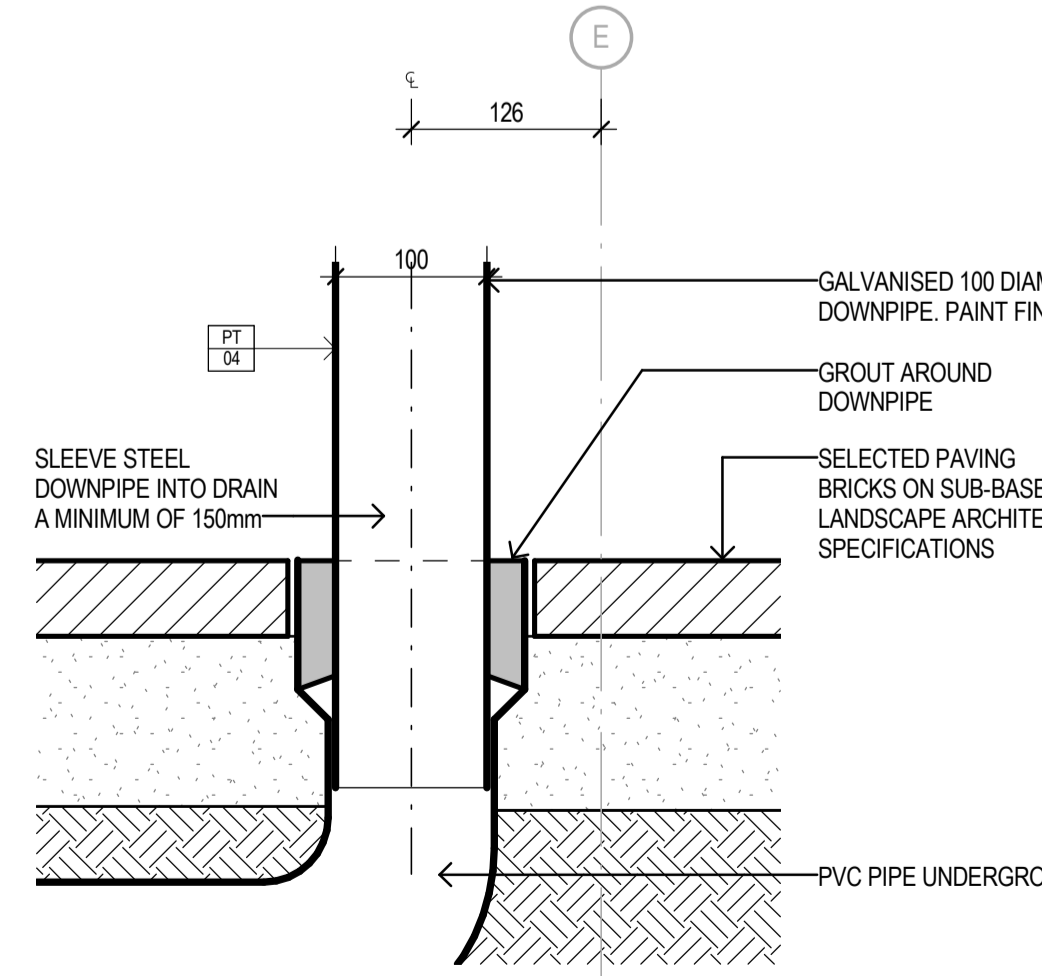

11 630\_SECTION\_TYPICAL DOWNPIPE BOTTOM DETAIL  
A501 1:5

North

**PRELIMINARY**  
NOT TO BE USED DURING CONSTRUCTION

E	CHANGE TO ACC. WC	16.10.14	CV	HS
D	ISSUED FOR CONSTRUCTION CERTIFICATE	31/07/13	AM	DD
C	95% CC ISSUE	26/07/13	AM	DD
B	PRELIMINARY ISSUE	23/07/13	AM	DD
A	50% CC ISSUE	15/07/13	AM	DD
Issue	Description	Date	Crk	Auth

Architect  
dwp/suters  
www.dwpsuters.com

Project  
JORDAN SPRINGS AMENITIES BUILDING

Location  
THE NORTHERN OVAL - JORDAN SPRINGS

Client  
CLOUSTON ASSOCIATES

Drawing  
CONSTRUCTION DETAILS - SHEET 2

Scale  
As indicated @ A1

Date Printed  
20/10/2014 12:08:12 PM

Project Number  
302673

Drawing Number  
A632

Issue  
E



File Name: C:\projects\REVIT\302673\302673\_CENTRAL\_NK.dwg